

SCAMBIATORI DI CALORE A DOPPIA PIASTRA TUBIERA FARMACEUTICI SERIE ASPH

DTS EXCHANGERS FOR PHARMACEUTICAL - ASPH MODEL

Gli scambiatori DTS per applicazioni farmaceutiche sono solitamente multitubo o multipasso. Sono realizzati a doppia piastra tubiera per evitare contaminazioni tra il fluido primario e il fluido secondario (standard FDA).

I tubi interni sono lisci con rugosità interna standard inferiore a 0,51 micron. Eventuali a richiesta inferiori a 0,4 micron. Materiali standard interamente in acciaio inox AISI316L 1.4404 o 1.4435. Il rivestimento esterno di coibentazione standard è realizzato in acciaio inox con finitura lucida completamente sigillata.

DTS exchangers for pharmaceutical applications are usually multi-tube or multi-pass. They are made with double tube plate to avoid contamination between the primary fluid and the secondary fluid (FDA standard).

The internal tubes are smooth with standard internal roughness less than 0.51 micron. Any on request less than 0.4 micron. Standard materials entirely in stainless steel AISI316L 1.4404 or 1.4435. The standard external insulation coating is made of stainless steel with a fully sealed polished finish.

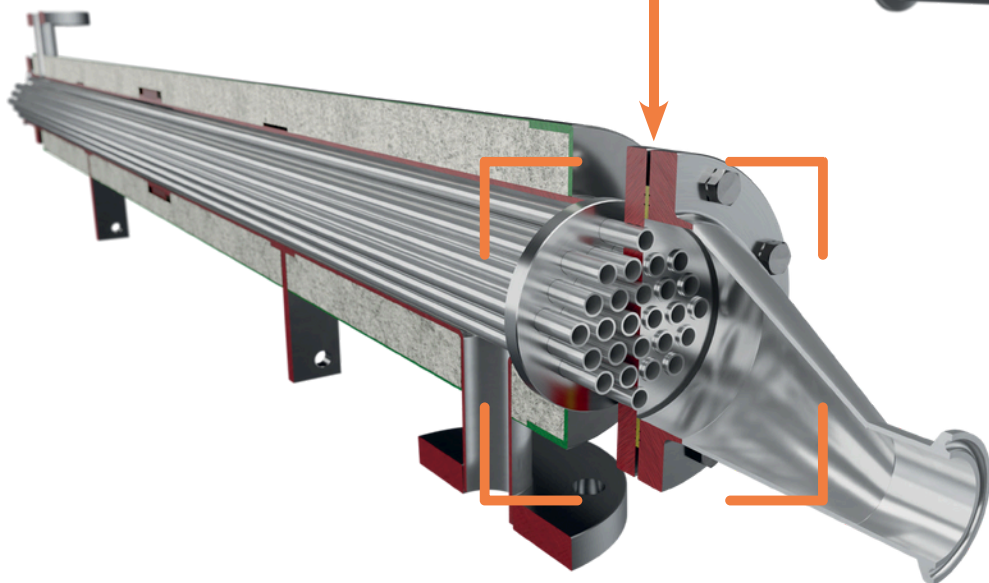

ASPH MODEL
PHARMA PHARMA

**SMC**
heat exchangers
SUPPORTO E DISTRIBUZIONE